

5200 MOUNT SERIES: 5200HT

Dimensions & Performance Characteristics

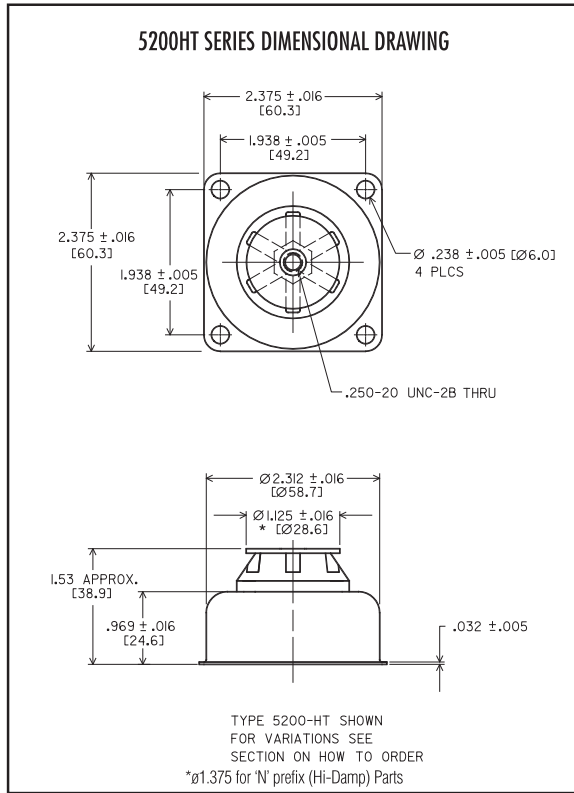

HOW TO ORDER 5200 SERIES ISOLATORS	
PLATE STYLE ISOLATORS (5200 SERIES)	CUP STYLE ISOLATORS (5200H SERIES)
<p>Letter N placed at beginning for Silicone Letter N placed at end for Neoprene (Absence of letter N indicates special natural rubber version)</p> <p><u>N</u> 5205-<u>T</u> <u>X</u> <u>N</u></p> <ul style="list-style-type: none"> • Use <u>T</u> for 1/4-20 UNC 2B threaded core • Leave <u>blank</u> for through hole • Use <u>X</u> for hex end of tapped core opposite 1.5 dia. ring • Use <u>Y</u> for hex end of tapped core on side nearest 1.5 dia. ring 	<p>Letter N placed at beginning for Silicone Letter N placed at end for Neoprene (Absence of letter N indicates special natural rubber version)</p> <p><u>N</u> 5205-<u>H</u> <u>T</u> <u>N</u></p> <ul style="list-style-type: none"> • <u>H</u> denotes cup-style version • Use <u>T</u> for 1/4-20 UNC 2B threaded core (hex is inside cup, opposite 1.5" dia. ring) • Leave <u>blank</u> for through hole